



Jurnal Teknologi Reaktor Nuklir

# Tri Dasa Mega

Journal homepage: [jurnal.batan.go.id/index.php/tridam](http://jurnal.batan.go.id/index.php/tridam)

## Analysis of Cogeneration Energy Conversion System Design in IPWR Reactor

Ign. Djoko Irianto\*, Sriyono, Sukmanto Dibyo, Djati Hoesen Salimy, Tukiran Surbakti, Rahayu Kusumastuti

Research Center for Nuclear Reactor Technology and Safety, BRIN, Kawasan Puspipstek Gd.80, Tangerang Selatan, 15314, Banten, Indonesia

### ARTICLE INFO

#### Article history:

Received: 19 July 2021

Received in revised form: 09 August 2021

Accepted: 10 August 2021

#### Keywords:

Energy Conversion System

Cogeneration

IPWR type reactor

ChemCAD

Energy Utilization Factor

### ABSTRACT

The acceleration of national development, especially in the industrial sector, requires an adequate national energy supply. There are various types of energy sources such as conventional energy sources, new and renewable energy sources including nuclear energy. The problem is how to utilize these energy sources into energy that is ready to be utilized. As a research and development institution in the nuclear field, BRIN has taken the initiative to contribute to the development of technology for providing electricity and other thermal energy, particularly reactor technology as a power plant and a provider of thermal energy. This research aims to analyze IPWR type SMR reactor design as a cogeneration energy conversion system. The IPWR reactor coolant as a cogeneration energy conversion system is arranged in an indirect cycle configuration or Rankine cycle. The primary cooling system and the secondary cooling system are mediated by a heat exchanger which also functions as a steam generator. The analysis was carried out by simulation using ChemCAD computer software to study the temperature characteristics and performance parameters of the IPWR as a reactor cogeneration energy conversion system. The simulation results show that the temperature of saturated steam coming out of the steam generating unit is around 505.17 K. Saturated steam is obtained in the reactor power range between 40 MWth to 100 MWth. Energy utilization factor (EUF) calculation shows that the IPWR cogeneration configuration can increase the energy utilization factor value up to 91.20%.

© 2022 Tri Dasa Mega. All rights reserved.

## 1. INTRODUCTION\*

To encourage national development, especially in the industrial sector, an adequate supply of national energy is urgently needed. Nationally, there are various energy sources, both conventional energy sources and new and renewable energy sources including nuclear energy. The problem is how to convert these energy sources into ready-to-use energy and

make the most of it while maintaining the preservation of various energy sources.

One solution to preserve the diversity of energy sources is to use them together or in a hybrid energy system between nuclear energy and other renewable energy sources[1, 2]. The concept of a hybrid energy system is implemented in the design of a cogeneration energy conversion system[3]

The current development of reactor designs tends to lead to the design of the reactor systems

\* Corresponding author :021-7560912

E-mail: [igndjoko@batan.go.id](mailto:igndjoko@batan.go.id)

DOI: 10.17146/tdm.2022.24.1.6414

which can be applied as a cogeneration system for power generation and the provision of heat energy[4–6]. Various countries have researched and developed various reactors as a future energy source used as a nuclear power plant (NPP), and as a supplier of heat energy for industry. As a research and development institution in nuclear technology, BATAN has long been concerned with the research and development of nuclear reactor systems to be applied as a primary energy supplier in Indonesia. Research and development carried out at BATAN regarding nuclear reactors system are focused on designing the cogeneration reactor system. A nuclear reactor with a cogeneration system can be used not only as a power plant. However, it can also use for the hydrogen production process, the desalination process, and others. The previous results of studies, research and developments regarding the nuclear reactor system are used to formulate a reactor system design concept that can be implemented in Indonesia.

Various types of reactors have been studied and researched to measure their chances of being implemented in Indonesia. Since 2010, BATAN has been developing a reactor system design based on a 200 MW thermal power of a High-Temperature Gas-cooled Reactor (HTGR) called RGTT200K[7]. The RGTT200K reactor system is designed in a cogeneration configuration for power generation and heat energy supply for hydrogen production.

Many aspects of the energy conversion systems have been studied and researched to support the design of the RGTT200K reactor. This study and research include; the cogeneration system in the RGTT200K energy conversion system, the effect of the mass flow rate of the coolant on the performance of the RGTT200K energy conversion system, and the application of the Brayton cycle[7] and Rankine cycle on the RGTT200K energy conversion system.

In addition to research for the development of the RGTT200K reactor design, research has also been carried out for the development of a 10 MW HTGR reactor design called the Non-Commercial Power Reactor (RDNK) or Experimental Power Reactor (RDE) [8, 9]. The RDNK reactor design development is based on building a non-commercial HTGR reactor in Serpong for experimental purposes. To support the development of the RDNK or RDE 10 MWt reactor design, various studies related to the high-temperature gas-cooled reactor (HTGR) technology and systems have been carried out. Besides experimental purposes, RDNK is also designed to supply electrical energy and heat energy for hydrogen production and/or desalination of seawater. Therefore, the RDNK energy conversion system designed as an indirect cycle can be arranged in a

cogeneration configuration. The RDNK reactor is designed with 10 MW thermal power, helium gas-cooled in the primary cooling cycle, and water-cooled in the secondary cooling cycle. Various studies to support the design of the 10 MWt RDNK have been carried out, including: on RDE steam generators[10, 11], also on cogeneration systems[12]

The current research is related to the study and development of small modular light water-cooled reactors (SMR) for cogeneration, specifically the integral pressurized water reactor (IPWR) type of SMR. Currently, around eleven types of IPWR type designs in the world, most of which are in the conceptual design development stage, some of which are already at the detailed design stage, some are even ready to be built[13]. Some IPWR reactor designs include; NuScale, IRIS, and mPower were designed by the US, and Korea designed SMART, and the NHR200-II was designed by China[14, 15]. The main distinguishing feature between the IPWR type SMR designs and the large reactors is implementing the integrated reactor cooling system (IRCS), and the multi-module implementation including the integrated control rod drive mechanism [13]. One of the concepts of the cogeneration energy conversion system based on IPWR is the NHR200-II. NHR (nuclear heating reactor) is an IPWR type reactor developed by the institute of nuclear and new energy technology (INET) of Tsinghua University. The NHR200-II is an IPWR reactor design with the model as a cogeneration energy conversion system for thermal energy supply and power generation[16].

This study aims to examine the characteristics of the IPWR type SMR reactor cogeneration energy conversion system. The IPWR type SMR reactor is considered to be developed to answer the challenges of energy needs in Indonesia, both electrical energy and thermal energy for industry. This research was conducted in a simulation both for the calculation of the energy utilization factor (EUF) and for calculating the characteristics of the IPWR cogeneration system. The simulation was carried out by the researcher using the ChemCAD computer program package.

## 2. THEORY

### 2.1. Reactor Cooling System of IPWR

Conceptually, one of the cooling system design models of the IPWR reactor is in a flow diagram shown in Figure 1[16]. The IPWR reactor cooling system diagram, as shown in Figure 1, also functions as an energy conversion system to supply energy to the energy user unit. The thermal energy generated from the reactor core is circulated in the primary loop and transferred to the secondary loop

by a heat exchanger, which also functions as a steam generator. The saturated steam generated from the steam generator flows into a steam turbine, where it is converted into mechanical energy which is then used to turn an electric generator to generate electricity. The cogeneration configuration is carried out by installing a heat exchanger at the steam turbine output. From this heat exchanger, the heat energy is transferred to the heat user unit. Thus, the heat energy produced from the reactor core is not only used as a power plant but also to supply energy in the form of heat energy through a heat exchanger.

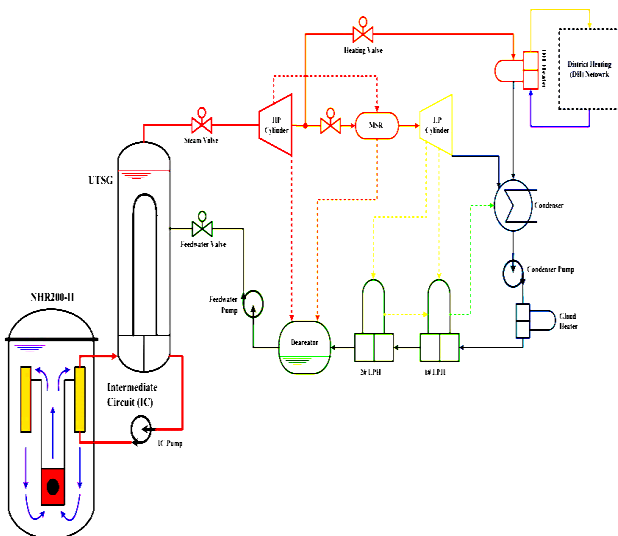

Fig 1. Brief diagram of the NHR200-II cogeneration system[16]

**2.2. Energy Utilization Factors and Thermal Efficiency.**

In general power plant installations, all the heat energy generated from the reactor is used for electricity generation. Since all thermal energy is used only for power generation, the total thermal efficiency of the entire system can be calculated using equation (1) as follows[17]:

$$\eta_t = \frac{\sum W_T - \sum W_C - \sum W_S}{Q_{in}} \times 100\% \dots\dots (1)$$

where  $\eta_t$  is the thermal efficiency value in energy conversion systems;  $\sum W_T$  is the work for all turbines (MW);  $\sum W_C$  is the power consumption of all compressors and/or pumps (MW);  $\sum W_S$  is the power consumption of all systems (MW), and  $Q_{in}$  is heat or power absorbed from the reactor (MW).

A cogeneration energy conversion system is an energy conversion system that can function as a power plant and a supplier of heat energy for industrial purposes. In the cogeneration system, the

performance calculation for the energy conversion system is not only on the ability to generate electricity but also the ability to provide heat energy for industry. Thus, the performance of the cogeneration energy conversion system can be expressed by two measures, namely: artificial thermal efficiency (ATE) and energy utilization factor (EUF)[18].

The efficiency for electricity generation in a cogeneration energy conversion system is referred to as artificial thermal efficiency. Artificial thermal efficiency is defined as thermal efficiency if the heat energy generated from the reactor is only used for electricity generation. The amount of artificial thermal efficiency also includes the efficiency of the electric generator and the mechanical energy efficiency of a rotating turbine. The thermal efficiency value for electricity generation in an energy conversion system that is only a power plant will be higher than artificial thermal efficiency in a cogeneration system. The artificial thermal efficiency value results from dividing the net output power for electricity generation by the total input energy minus the heat energy output divided by the boiler efficiency as shown in equation (2) as follows[19].

$$ATE = \frac{P_{net}}{Q_f - Q_h / \eta_{b,ref}} \dots\dots\dots(2)$$

where  $P_{net}$  is the unit net power output (MW);  $Q_f$  is the total fuel input energy (MW);  $Q_h$  is the unit's net heat output (MW), and where  $\eta_{b,ref}$  is the efficiency of the boiler.

In a cogeneration energy conversion system, the system performance is calculated based on the energy utilization factor (EUF) value, which includes all units that utilize thermal energy from the reactor. The EUF value is always higher than the thermal efficiency value of the energy conversion system. The higher the EUF value indicates the economic value of the cogeneration energy conversion system, which also means the more efficient use of fuel. The EUF value for the energy conversion system can be calculated using the following equation (3) [20]:

$$EUF = \frac{P_{net} + Q_h}{Q_f} \times 100\% \dots\dots\dots (3)$$

where EUF is the value for the energy utilization factor;  $P_{net}$  is the net power output from the power generating unit (MW);  $Q_h$  is the net power output for the unit utilizing thermal energy (MW), and  $Q_f$  is the reactor thermal power (MW).

### 3. METHODOLOGY

In this study, an analysis for the design of the IPWR reactor cogeneration energy conversion system with an indirect cycle configuration was carried out. The analysis is carried out by calculating the performance parameters including energy balance, power load distribution, and temperature distribution in each of the main components of the cogeneration energy conversion system and energy utilization factor (EUF).

The analysis of the design of the IPWR reactor cogeneration energy conversion system and calculation of the performance parameters conducted by the following stages:

1. By considering various possible configurations and geometric data of the IPWR type reactor cogeneration energy conversion system, the IPWR type reactor cogeneration energy conversion system configuration was determined as shown in Figure 1.
2. Modeling of the IPWR type reactor cogeneration energy conversion system as shown in Figure 1 using the ChemCAD computer program. The results of modeling the IPWR type reactor cogeneration energy conversion system using ChemCAD are shown in Figure 2.
3. Determination of the main component parameters and a simulation of the performance calculation of the cogeneration energy conversion system are carried out. Simulations were carried out for steady conditions with the addition of thermal power gradually from 10 MW to 100 MW.
4. It is analyzing the simulation data and calculating the performance parameters of the indirect cycle IPWR type reactor cogeneration energy conversion system and its main components. The calculation of performance parameters focused on calculating the energy utilization factor (EUF).

### 4. RESULTS AND DISCUSSION

In this study, a simulation for the IPWR reactor cogeneration energy conversion system using ChemCAD has been carried out. The simulation aims to study the characteristics of the IPWR energy conversion system by comparing the simulation results with the parameters in the

literature. The IPWR cogeneration energy conversion system model made using ChemCAD is shown in Figure 2. According to the literature data, the parameters of the primary coolant mass flow rate and the primary coolant pressure and the secondary coolant mass flow rate, and the secondary coolant pressure were determined. The reactor power is increased gradually from 10 MWth to 100 MWth. The comparison of the main parameters of the 100 MWth IPWR Energy Conversion System between the simulation results and the parameters contained in the literature is shown in Table 1. The temperature characteristics of the simulation results of the cogeneration energy conversion system are shown in Figure 3, Figure 4, and Figure 5.

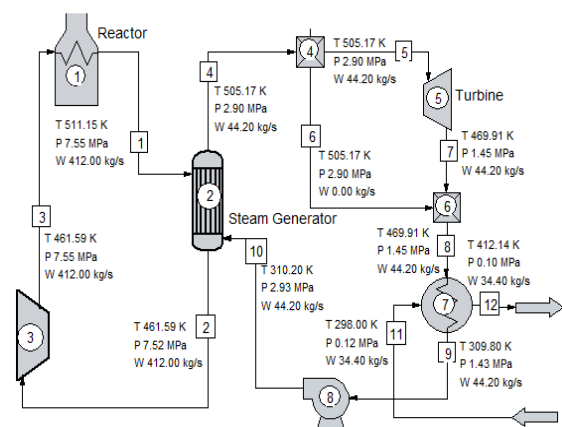

**Fig 2.** IPWR type reactor cogeneration energy conversion system model using ChemCAD

**Table 1.** Comparison of the main parameters of the IPWR type reactor cogeneration energy conversion system between the simulation results and literature data [21].

Parameter	Unit	Value	
		Literature	simulation
Reactor thermal power	MWth	100	100
Primary loop pressure	MPa	7.55	7.55
Reactor core inlet temperat	K	510	509.06
Reactor core outlet temper	K	558	557.35
Primary coolant mass flow	kg/s	412	412
Steam Pressure	MPa	2.9	2.9
Secondary coolant mass flow rate	kg/s	44.2	44.2
Steam generator inlet temperature	K	423	420.39
Steam generator outlet temperature	K	536	535.66

Table 1 shows that some of the main parameters of the IPWR type reactor cogeneration energy conversion system between the simulation results

using ChemCAD and the literature data have almost the same value. Thus, the simulation of the IPWR type reactor cogeneration energy conversion system using ChemCAD is reliable.

The simulation was carried out by maintaining the mass flow rate and pressure parameters on the primary cooling and secondary cooling sides. Changes are only made to the reactor's thermal power by adding 5 MWth of power gradually from 10 MWth to 100 MWth of reactor power. In this simulation, all-temperature changes in the primary and secondary coolants are recorded. In addition to temperature, changes in power are also observed in each of its main components.

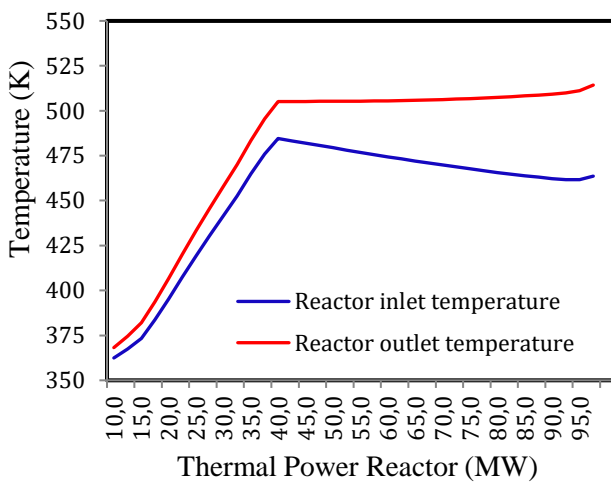

Fig 3. Temperature characteristics at the inlet and outlet of the reactor

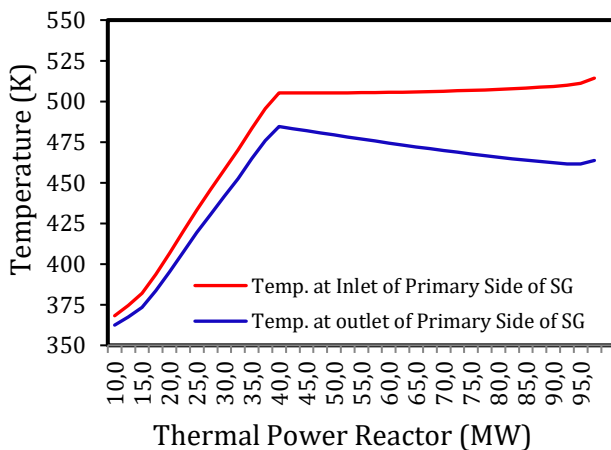

Fig 4. Temperature characteristics of the primary side Steam generator

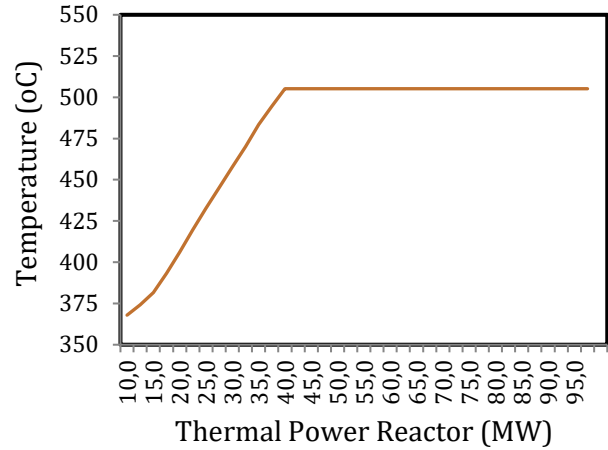

Fig 5. Graph of steam temperature from the steam generator unit.

Figure 3 shows the characteristics of the inlet and outlet temperatures of the reactor, while Figure 4 shows the characteristics of the inlet and outlet temperatures of the steam generator on the primary side. From the two figures, it can be explained that at low reactor power, heat energy from the reactor is used to increase the temperature of the primary coolant. Stable conditions can be achieved at a reactor power of about 40 MWth, at that power the reactor output temperature is around 500 K. After a stable condition is reached, the increase in reactor power does not affect the temperature increase at the outlet side of the reactor.

Figure 5 shows a graph of the temperature characteristics at the steam generator output on the secondary cooling side. The graph in Figure 5 shows that stable conditions were reached at a reactor power of around 40 MWth. At a reactor power of less than 40 MWth, the steam coming out from the steam generator unit is still mixed with water. After the reactor power is about 40 MWth, there is no more temperature rise, the steam generated from the steam generating unit has reached the saturated steam level. With this saturated steam, the steam turbine installed in the secondary loop can work optimally. Saturated steam is obtained at reactor power between 40 MWth to 100 MWth. Using equation (2) for the configuration of the cogeneration energy conversion system as shown in Figure 2 shows that the EUF value is 91.20%.

## 5. CONCLUSION

This research has studied the characteristics of the cogeneration energy conversion system for the IPWR reactor. The research was conducted in a simulation using the ChemCAD computer

program. From the simulations results, the temperature of the saturated steam coming out of the steam generating unit is 505.17 K. Saturated steam is obtained at reactor power between 40 MWth to 100 MWth. Furthermore, simulation results and calculations on the energy utilization factor (EUF) show that the IPWR cogeneration configuration can increase the value of the energy utilization factor up to 91.20%.

## ACKNOWLEDGMENT

All authors would like to thank the Center for Technology and Nuclear Reactor Safety (PTKRN) - BATAN for their permission, we can all research the IPWR energy conversion system.

## AUTHOR CONTRIBUTION

All authors have equal contributions to this paper as main contributors. Ign. Djoko Irianto conducted the assessment and writing the manuscript. Rahayu Kusumastuti prepared data for simulation. Sriyono and Djati H. Salimy provided the necessary literature sources, and Tukiran Surbakti and Sukmanto Dibyo reviewed the manuscript and gave suggestions to improve the manuscript.

## REFERENCES

1. Abdussami M.R., Adham M.I., Gabbar H.A. Modeling and Performance Analysis of Nuclear-renewable Micro Hybrid Energy System Based on Different Coupling Methods. *Energy Reports*. 2020. **6**:189–206.
2. Gabbar H.A., Abdussami M.R., Adham M.I. Techno-economic Evaluation of Interconnected Nuclear-renewable Micro- hybrid Energy Systems with Combined Heat and Power. *Energies*. 2020. **13**(7):1642.
3. Schmidt J.M., Gude V.G. Nuclear Cogeneration for Cleaner Desalination and Power Generation – A Feasibility Study. *Clean. Eng. Technol*. 2021. **2**:100044.
4. Pirmohamadi A., Ghazi M., Nikian M. Optimal Design of Cogeneration Systems in Total Site Using Energy Approach. *Energy*. 2019. **166**:1291–302.
5. Sato H., Yan X.L. Study of an HTGR and Renewable Energy Hybrid System for Grid Stability. *Nucl. Eng. Des*. 2019. **343**:178–86.
6. Verfondern K., Yan X., Nishihara T., Allelein H. Safety Concept of Nuclear Cogeneration of Hydrogen and Electricity. *Int. J. Hydrogen Energy*. 2017. **42**(11):7551–9.
7. Irianto I.D. Design And Analysis Of Helium Brayton Cycle For Energy Conversion System Of RGTT200K. *Tri Dasa Mega*. 2016. **18**(2):75–86.
8. Irianto I. D., Dibyo S., Sriyono, Salimy D. H., Kusumastuti R., Pujiastuti E., et al. Performance Analysis on the Design of the Energy Conversion System of the Indonesia Experimental Power Reactor. *AIP Conf. Proc*. 2019. **2180**: 020031.
9. Dibyo S., Irianto I.D., Bakhri S. Comparison on Two Option Design of The RDE Cogeneration System. *J. Phys.: Conf. Ser*. 2019. **1198**:022039.
10. Kadarno P., Riyandwita B.W., Sriyono, Irianto I. D. Effect of Helium Purification System Intake Pipe on Pressure Drop of HTGR Steam Generator. *AIP Conf. Proc*. 2019. **2180**: 020030.
11. Dibyo S., Irianto I.D. Design Analysis on Operating Parameter of Outlet Temperature and Void Fraction in RDE Steam Generator. *Tri Dasa Mega*. 2017. **19**(1):33–40.
12. Irianto I. D., Dibyo S., Sriyono S., Salimy D. H., Kusumastuti R., Pancoko M. Performance Analysis of RDE Energy Conversion System in Various Reactor Power Condition. *Tri Dasa Mega*. 2019. **21**(3):99–106.
13. Zeliang C., Mi Y., Tokuhiko A., Lu L., Rezvoi A. Developmental Status, Design Characteristics and. *Energies*. 2020.
14. Priego E., Alonso G., del Valle E., Ramirez R. Alternatives of Steam Extraction for Desalination purposes using SMART Reactor. *Desalination*. 2017. **413**:199–216.
15. Dong Z., Pan Y. A Lumped-parameter Dynamical Model of a Nuclear Heating Reactor Cogeneration Plant. *Energy*. 2018. **145**:638–56.
16. Dong Z., Liu M., Jiang D., Huang X., Zhang Y., Zhang Z. Automatic Generation Control of Nuclear Heating Reactor Power Plants. *Energies*. 2018. **11**(10)
17. Xinhe Q., Xiaoyong Y., Jie W., Gang Z. Combined Cycle Schemes Coupled with a Very High Temperature Gas-cooled Reactor. *Prog. Nucl. Energy*. 2018. **108** (4):1–10.
18. Jannelli E., Minutillo M., Cozzolino R., Falcucci G. Thermodynamic Performance Assessment of a Small Size CCHP (Combined Cooling Heating and Power) System with Numerical Models. *Energy*. 2014. **65**:240–249.
19. Chen H., Wu Y., Xu J., Xu G., Yang Y., Liu W., et al. Thermodynamic and Economic Analyses of Reformative Design for High Back-Pressure Heating in Coal-Fueled Cogeneration Units. *Entropy*. 2019. **21**(4):342.
20. Pradeep Varma G. V., Srinivas T. Design and Analysis of a Cogeneration Plant Using Heat Recovery of a Cement Factory. *Case Stud. Therm. Eng*. 2015. **5**:24–31.

21. Khan S.U. Transient Analysis of Integral Pressurized Water Reactor (IPWR). Int. Conf. Nucl. Energy New Eur. 2013. **4**:1–8.

