



Jurnal Teknologi Reaktor Nuklir

Tri Dasa Mega

Journal homepage: jurnal.batan.go.id/index.php/tridam

Critical Heat Flux Nanofluids Measurements System Using Arduino

Santiko Tri Sulaksono*, Sudjatmi Kustituantini Alfa, Dani Gustaman Syarif

Center for Applied Nuclear Science and Technology - BATAN, Jalan Tamansari No. 71 Bandung 40132, Indonesia

ARTICLE INFO

Article history:

Received: 3 September 2020

Received in revised form: 26 November 2020

Accepted: 27 November 2020

Keywords:

Critical heat flux

Nanofluids

Arduino

Voltage

Current

ABSTRACT

Critical heat flux (CHF) is an important characteristic of nanofluids. The CHF measurements were carried out in nanofluid research at the Center for Applied Nuclear Science and Technology. These measurements are done manually using a variable power supply and a multimeter. However, it was difficult to record the voltage and current due to the sudden break of the wire. In this study, Arduino was used to measure CHF automatically. The voltage is applied to the wire and increases automatically along with the measurement of the voltage and current in the wire. The results of the voltage and current measurements were compared with a multimeter and were not significantly different. It can be concluded that the CHF measurement system using arduino can be used to measure nanofluid CHF.

© 2021 Tri Dasa Mega. All rights reserved.

1. INTRODUCTION

Heat transfer is a physical phenomenon that is widely used for various devices including nuclear reactors, automotive, and industrial machines. In these devices, heat transfer occurs using a cooling system to keep it at working temperature. Developments are being made so that the cooling system works optimally and safely by increasing the rate of cooling fluid and using nanofluids as coolants.

Nanofluid research is carried out in the technophysics laboratory of the Center for Applied Nuclear Science and Technology. One of the studies carried out is the synthesis and characterization of Al_2O_3 nanofluids because it has low neutron absorption properties so that it can be applied in the nuclear field [1–4]. CHF (critical heat flux) is an important characteristic of nanofluids. In previous studies, CHF measurements used a power

supply and multimeter or data acquisition system. Madshuree uses an Aplab H3100 regulated power source for wire and a Keithley 195A programmable DMM (Digital Multimeter) for measuring the voltage and current flowing in the wire[5]. Sheikhbahai uses a High Voltage power supply and a DEC330F multimeter[6]. Hiswankar uses AC 230V 50A power source for wire and National Instrument data acquisition for measurement of voltage and current flowing in wire[7]. Kim uses Sorensen DLM 300–13E power supply and Agilent 34970A data acquisition system[8]. Hendricks uses NI-DAQ system[9].

To get CHF, a current and voltage value is needed when the resistance of the wire increases sharply or when the wire breaks. This is very difficult if the measurement does not use a data acquisition system that records the current and voltage during the measurement. Therefore, in this study, a CHF measurement system was created that automatically transmits and increases the power of the wire and measures and records the voltage and current on the wire. The measurement system is built using inexpensive and commonly used

* Corresponding author. Tel./Fax.: 085692722797

E-mail: santiko@batan.go.idDOI: [10.17146/tdm.2021.23.1.6005](https://doi.org/10.17146/tdm.2021.23.1.6005)

modules and components. The system is tested by measuring the current and voltage on the wire and compared with the measurements using a multimeter. The results of this study are expected to be used to measure CHF in nanofluid research in technophysics laboratories.

2. THEORY

The CHF measurement is done by applying a voltage to a thin wire in the nanofluid so that an electric current flows through the wire. When the applied voltage is increased, the electric current in the wire will increase and the heat generated by the wire will also increase. The heat flux produced by the wire depends on the dimensions of the wire, the potential difference between the ends of the wire and the current in the wire. Calculation of the heat flux in the wire is as follows[5, 7, 10]:

$$q'' = \frac{VI}{\pi D l} \quad (1)$$

where V, I, D and l are the voltage in the wire, the current in the wire, the diameter of the wire and the length of the wire.

In conditions of maximum heat transfer from the surface of the wire to the nanofluid, there is a rapid increase in heat in the wire so that the wire breaks. The heat flux when the wire breaks is CHF.

Arduino board is a multipurpose microcontroller module that is open source both in terms of hardware and software. One of the Arduino products that is commonly used is the Arduino uno which uses the ATmega 328 microcontroller. The Arduino uno has 14 digital inputs and 6 analog inputs with a crystal speed of 16 MHz, features 3 counters / timers, 6 Pulse Width Modulation(PWM) outputs, Analog to Digital Converter, and external and internal interrupts. With an inexpensive price, the Arduino uno can be used for various measurements using sensors and can be a simple control system.

PWM signal is a digital pulse modulation that changes the pulse width, as well as its duty cycle[11, 12]. The PWM output setting on the Arduino is done by assigning a value to the output pin with a value range of 0 to 255. In the Arduino IDE, the program line used to provide PWM values is analogWrite (pin, value). PWM on the Arduino is widely used to control DC motor speed such as fan rotation control to wheel-based robot control[12–14].

3. METHODOLOGY

CHF measurement system design consists of hardware and software design. The hardware

consists of a 12V 30A power supply, 5V regulator, arduino, amplifier circuit, ACS712 current sensor module and PC. The software is created using the Arduino IDE and Processing IDE for Arduino process control and user interface. The block diagram of the CHF measurement design is shown in Figure 1.

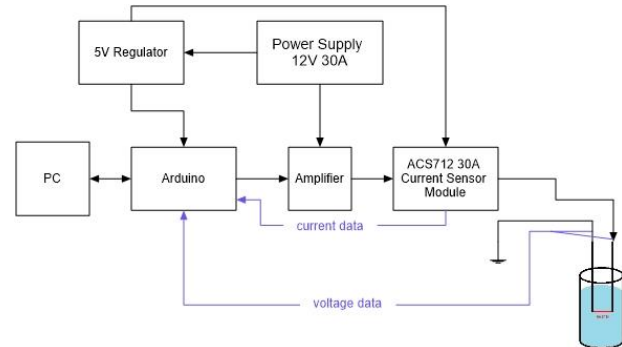

Fig. 1. Block diagram of the CHF Measurement

The Arduino D11 pin is connected to the amplifier then through the ACS712 current sensor module to the wire inside the nanofluid. D11 is set to be the output pin to generate a PWM signal. Figure 2 shows the schematic of the amplifier circuit in the CHF measurement system. The PWM signal at pin D11 is converted to DC voltage by the opamp, then the voltage is amplified by another opamp. Four Darlington pairs amplify the opamp output voltage and current until the output on the JP1 connector can reach 12 Volt 30 A. Thus, the current and voltage on the wire connected to JP1 can be controlled by adjusting the PWM value on pin D11. The current in the wire is measured using the ACS712 module at each PWM value. In addition, the voltage is also measured by connecting the two ends of the wire to the Arduino analog pin.

The electric current flowing in the wire is also measured using the ACS712 module which can measure an electric current of up to 30 A. The measured current enters this module and passes through the copper conduction path inside the module to produce a magnetic field. This magnetic field is measured by the Hall sensor in the IC then converted into a voltage. The ACS712 IC in the module made by Sparkfun has a measurement sensitivity of 66 mV/A[15]. The module produces a voltage of 2.5 V at a current of 0 A and increases ± 66 mV per 1 A of current. The ACS712 module output is connected to the analog pin A0 Arduino. The measured voltage on A0 is then calculated into the current value by the program to be stored on the computer and displayed on the screen.

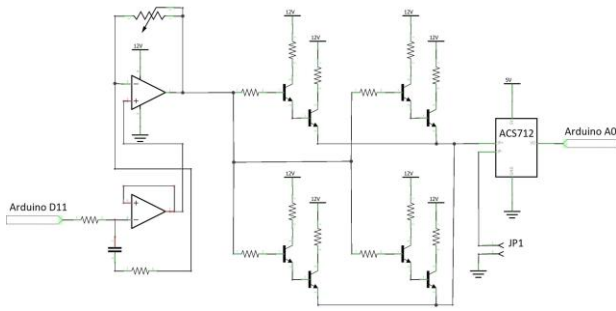

Fig. 2. Amplifier circuit of the CHF measurement system

PWM output control, current and voltage measurements are carried out by software using the Arduino IDE and Processing IDE programs. Arduino IDE is a software tool for making processes carried out by Arduino using the C language while the Processing IDE is a multipurpose software tool that also uses the C language. Both of these software tools are used to create arduino control processes and also interface with users. For this reason, Arduino implements a firmware program called Firmata through the Arduino IDE, while control processes such as automatic wire power enhancement and voltage measurement, and interfaces are created on the Processing IDE. Flowchart of the CHF measurement system software process can be seen in Figure 3.

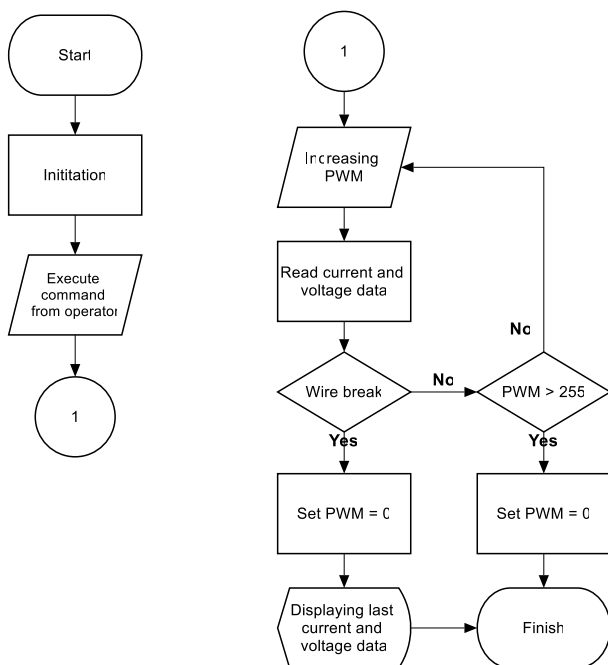

Fig. 3. Flowchart of the CHF measurement system software process

The interface program will send a command signal to Arduino when the user presses the button to start, then Arduino will add a value to the PWM

port. Arduino measures the voltage and current then sends it to the computer to be displayed and stored in the interface program. If there is no significant increase in voltage or decrease in wire current, which indicates the wire is broken, Arduino then increases the PWM value, measures the voltage and current and sends data to the computer. When the wire breaks, the Arduino will stop power to the wire by giving a PWM value of 0 and sending a signal to the computer that the measurement is complete. However, if the wire is not broken, the PWM value will reach a maximum of 255 and the program will stop measuring. This can happen due to incorrect wire dimensions. In order for it to break, the wire used must be thin and short enough.

4. RESULTS AND DISCUSSION

The test is done by measuring the output pressure of the first opamp. Measurements are made for each increase in the PWM value in the range of 40 to 255. The output voltage of the first opamp is measured when the PWM value is in a multiple of 40. Figure 4 is a graph of the measurement results of the first opamp output with a PWM value. From the graph, it can be seen that the output of the first opamp is a direct current voltage which increases linearly. The maximum output voltage of the first opamp is 4.9 volts. This shows that the opamp can convert the PWM signal into direct current voltage.

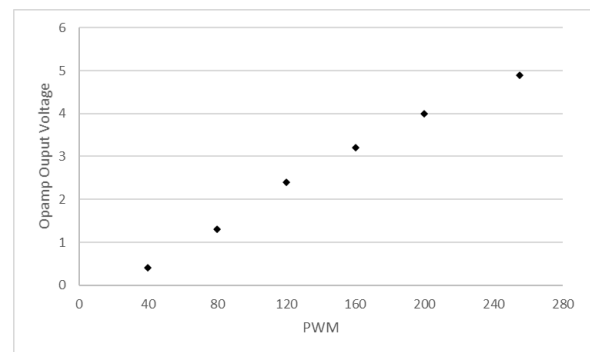

Fig. 4. Arduino PWM and opamp output signal

The output voltage of the first opamp is amplified in the second opamp. Figure 5 shows a graph comparing the output of the first opamp to the second opamp. From the graph, it can be seen that the second opamp voltage is amplified about 2 times from the first opamp's output. The amount of gain can be adjusted using a variable resistor in the second opamp circuit in order to produce optimum gain. Both of these opamps are in 1 IC LM358.

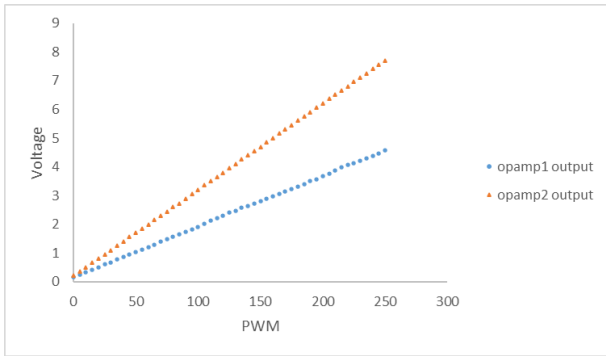

Fig. 5. Opamp output voltage

Measurements are then made by connecting the system to a thin copper wire that is placed horizontally in the water. The value of the voltage and electric current on the wire is measured and compared with measurements using a digital multimeter Constant 50. The voltage and current data before the wire break is displayed in an interface program on the computer.

Voltage measurement is done by connecting one end of the wire with analog pin A1 and the other end to pin A2 Arduino. Measurement of the wire potential difference is also carried out using a multimeter. Comparison of measurement results can be seen in Figure 6. In the graph, it can be seen that the potential difference in the wire starts to increase when the PWM value is more than 40. The Arduino measurement results are not significantly different from the multimeter measurement results, but the error occurs due to the electrical noise. In further development it is necessary to add a filter circuit for voltage measurement. The comparison of the voltage measurement results between the CHF measurement system and the multimeter can be seen in table 1. The average value of the deviation between the two measurements is 0.031 mV with a maximum deviation of 0.145 mV.

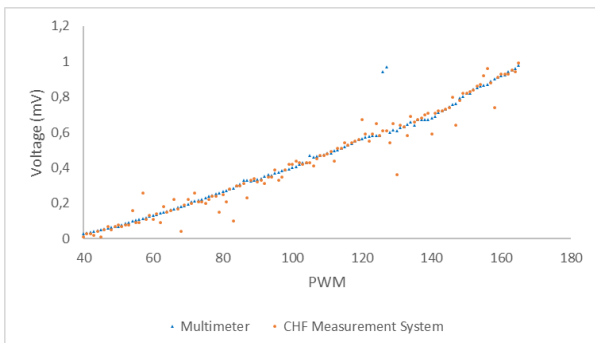

Fig. 6. Wire voltage measurement

Table 1. Comparison of voltage measurement results

| PWM | Multimeter (mV) | CHF Measurement System (mV) | Deviation |
|-----|-----------------|-----------------------------|-----------|
| 30 | 0.0013 | 0 | 0.0013 |
| 40 | 0.027 | 0.01 | 0.017 |
| 50 | 0.07 | 0.08 | 0.01 |
| 60 | 0.132 | 0.11 | 0.022 |
| 70 | 0.193 | 0.22 | 0.027 |
| 80 | 0.265 | 0.25 | 0.015 |
| 90 | 0.334 | 0.32 | 0.014 |
| 100 | 0.4 | 0.42 | 0.02 |
| 110 | 0.483 | 0.48 | 0.003 |
| 120 | 0.562 | 0.67 | 0.108 |
| 130 | 0.61 | 0.36 | 0.25 |
| 140 | 0.68 | 0.59 | 0.09 |
| 150 | 0.82 | 0.82 | 0 |
| 160 | 0.92 | 0.93 | 0.01 |

Figure 7 is a graph comparing the results of current measurements using Arduino with a multimeter. The current in the wire starts to flow at a PWM value of more than 40 and continues to increase. The current measured with the Arduino is not much different from the multimeter measurement. The comparison of the current measurement results can be seen in table 1. The average value of the deviation between the two measurements is 0.129 A with a maximum deviation of 1.21 A.

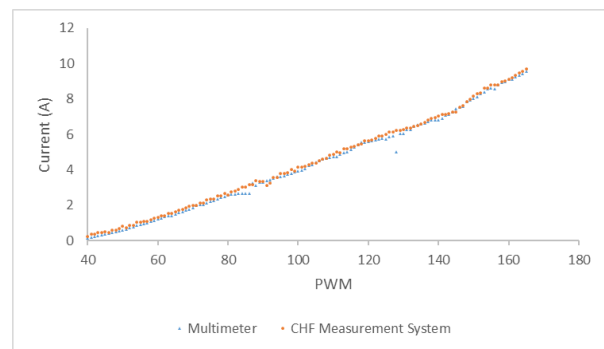

Fig. 7. Wire current measurement

Table 2. Comparison of current measurement results

| PWM | Multimeter (A) | CHF Measurement System (A) | Deviation |
|-----|-------------------|----------------------------------|-----------|
| 30 | 0.13 | 0 | 0.13 |
| 40 | 0.13 | 0.23 | 0.1 |
| 50 | 0.6 | 0.82 | 0.22 |
| 60 | 1.22 | 1.34 | 0.12 |
| 70 | 1.84 | 2 | 0.16 |
| 80 | 2.57 | 2.59 | 0.02 |
| 90 | 3.31 | 3.33 | 0.02 |
| 100 | 3.92 | 4.15 | 0.23 |
| 110 | 4.75 | 4.89 | 0.14 |
| 120 | 5.58 | 5.63 | 0.05 |
| 130 | 6.04 | 6.29 | 0.25 |
| 140 | 6.8 | 7.03 | 0.23 |
| 150 | 8.03 | 8.14 | 0.11 |
| 160 | 9.09 | 9.1 | 0.01 |

5. CONCLUSION

The CHF measurement system using the Arduino has been built and tested. The system can increase the voltage on the wire gradually and automatically after the command to start measuring is given, this has been proven based on the results of comparisons with a multimeter. The value of the voltage and electric current on the measured wire, stored and displayed on the screen. After the wire breaks, the voltage and current measurement data just before the wire breaks is displayed on the screen and the power supply to the wire is stopped. The comparison of the system measurement data with the multimeter measurement results is not significantly different. Therefore, the arduino-based CHF measurement system can be used to measure nanofluid CHF instead of manual measurement.

ACKNOWLEDGMENT

The authors would like to express special thanks to the Center for Applied Nuclear Science and Technology which has supported this work through the DIPA PSTNT in 2015-2019. Also thanks to colleagues in the Technophysics Division for their support.

AUTHOR CONTRIBUTION

Santiko Tri Sulaksono contributed as the main contributors of this paper. All authors read and approved the final version of the paper.

REFERENCES

1. Syarif D.G., Prajitno D.H., Pane J.S. Nanofluids with Enhanced CHF Prepared from Solgel Synthesized Al₂O₃ Nanoparticles Utilizing Urea as Chelating Agent. 2018. 1:801-814.
2. Syarif D.G., Prajitno D.H., Pane J.S. Nanofluids with Enhanced CHF Prepared from Self-Combustion Synthesized Al₂O₃ Nanoparticles with PEG 1000 as Fuel. IOP Conf. Ser. Mater. Sci. Eng. 2019. **515**:1-8.
3. Syarif D.G., Prajitno D.H., Umar E. Characteristics of Nanofluids Made from Solgel Synthesized-Al₂O₃ Nanoparticles using Citric Acid and PEG as Organic Agent and Bauxite as Raw Material. Mater. Sci. Forum. 2018. **929**:1-9.
4. Syarif D.G., Prajitno D.H., Pane J.S. Effect of Calcination Temperature during Synthesis of Al₂O₃ from Local Bauxite on Stability and CHF of Water-Al₂O₃ Nanofluids. J. Aust. Ceram. Soc. 2018. **54**(1):47-53.
5. Kole M., Dey T.K. Investigations on the Pool Boiling Heat Transfer and Critical Heat Flux of ZnO-ethylene glycol nanofluids. Appl. Therm. Eng. 2012. **37**:112-119.
6. Sheikhabahai M., Nasr Esfahany M., Etesami N. Experimental Investigation of Pool Boiling of Fe₃O₄/Ethylene Glycol-water Nanofluid in Electric Field. Int. J. Therm. Sci. 2012. **62**:149-153.
7. Hiswankar S.C., Kshirsagar J.M. Determination Of Critical Heat Flux In Pool Boiling Using ZnO Nanofluids. 2013. **2**(7):2091-2015.
8. Kim S.H., Lee G.C., Kang J.Y., Moriyama K., Kim M.H., Park H.S. Boiling Heat Transfer and Critical Heat Flux Evaluation of the Pool Boiling on Micro Structured Surface. Int. J. Heat Mass Transf. 2015. **91**:1140-1147.
9. Hendricks T.J., Krishnan S., Choi C., Chang C.H., Paul B. Enhancement of Pool Boiling Heat Transfer using Nanostructured Surfaces on Aluminum and Copper. ASME Int. Mech. Eng. Congr. Expo. Proc. 2010. **12**:1025-1033.
10. Park S.D., Lee S.W., Kang S., Kim S.M., Bang I.C. Pool Boiling CHF Enhancement by Graphene-oxide Nanofluid under Nuclear Coolant Chemical Environments. Nucl. Eng. 2012. **252**:184-191.
11. Meade T. Pulse Width Modulation Using an Arduino. 2014. :1-8.
12. Birdayansyah R., Soedjarwanto N., Zebua O. Pengendalian Kecepatan Motor DC Menggunakan Perintah Suara Berbasis Mikrokontroler Arduino. Electrician. 2015. **9**(2):97-108.
13. Petru L., Mazen G. PWM control of a DC Motor used to Drive a Conveyor Belt. Procedia Eng. 2015. **100**:299-304.
14. Kaushik S., Chouhan Y.S., Sharma N., Singh

- S. Automatic Fan Speed Control using Temperature and Humidity Sensor and Arduino. *Int. J. Adv. Res.* 2018. **4**(2):453-467.
15. Allegro® ACS712. 2020.:1-15.